

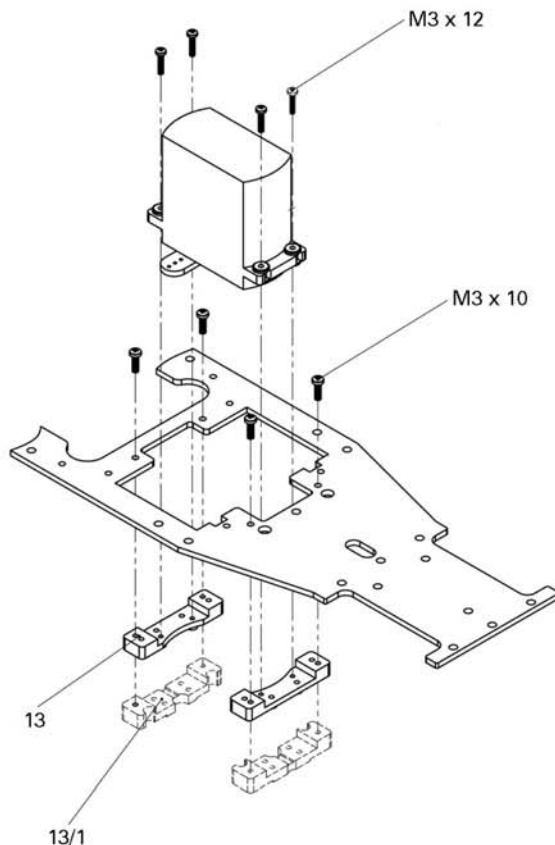

Wild Hunter	# 1571100
	V. 1.0 01.08.2008

Einbau des Lenkservos und der Empfangsanlage Mounting servo and receiver Installation du servo de direction et du récepteur



Bitte beachten Sie, dass das verwendete Lenkservo über genug Stellkraft verfügt.
Es sollten mindestens 150 Ncm bei 6V zur Verfügung stehen. Dem Chassis liegen zwei verschiedene Typen von Servohalteplatten bei:

Nr.: 1572020 für Carson HP-Mega Servo oder Hitec 805
Nr.: 1572022 für Hitec 5745 oder MPX Rhino bzw. Jumbo

Montieren Sie zuerst die passenden Servohalteplatten mit den beiliegenden M 3x10 Schrauben. Anschließend wird das Servo festgeschraubt.

Please make sure that the steering servo is strong enough, at least 150 Ncm with 6 V. The chassis comes stock with two different servo mounts:

No.: 1572020 for Carson HP-Mega Servo or Hitec 805
No.: 1572022 for Hitec 5745 or MPX Rhino respectively Jumbo

Please fix the servo mounts by means of the screws M 3 x 10 attached. After that fix the servo.

Veillez impérativement à ce que la force du servo de direction soit suffisante : 150 Ncm avec 6V au minimum. Le châssis est livré avec deux supports de servo :

No.: 1572020 pour Carson HP-Mega Servo ou Hitec 805
No.: 1572022 pour Hitec 5745 ou MPX Rhino ou plutôt Jumbo

Fixez les supports de servo avec les vis M 3x10 fournies. Ensuite fixez le servo.

Hinweise zur Fernsteuerung und Empfängerakku Information concerning radio and receiver battery Renseignement concernant radio et accu récepteur

Wir empfehlen unbedingt eine FM-Fernsteuerung zu verwenden, da diese Fernsteuerungen wesentlich störsicher sind und über mehr Reichweite verfügen.

Der Empfänger sollte mit etwas Schaumstoff vibrationsgeschützt in der Empfängerbox gelagert werden.

Ein wichtiger Punkt für die korrekte Funktion des Fahrtenreglers und der Empfangsanlage ist ein hochwertiger 6V Empfängerakku.

Wir empfehlen die Empfängerakkus Nr.: 1511903 oder 1511903-1, die auch genau in den Empfängerakkualter passen. Der Akku sollte mit dem Anschlusskabel Nr. 1511900 an den Empfänger angeschlossen werden. Herkömmliche Schalterkabel, wie sie in den Fernsteuerungssets enthalten sind, sind nicht geeignet

Wichtig: Falls der Empfängerakku über nicht genügend Leistung verfügt, kommt es zu Fehlfunktionen des Fahrtenreglers!

We recommend to use a FM-radio as such radios have a long range and are much more resistant against interferences.

The receiver should be put into the receiver box protected against vibrations by some foam.

Also important for the trouble free function of radio and controller is a high quality 6 V receiver battery. We recommend to use the receiver batteries no. 1511903 or 1511903-1 which fit both perfectly into the battery mount delivered with the car. The battery pack has to be connected with the receiver by means of the connection cable no. 1511900. Conventional connection cables as they come stock with radio sets are not suitable.

Attention: If the receiver battery has not enough power this will lead to malfunctions with the speed controller.

Nous recommandons d'utiliser une radio FM, car ces radios sont moins sujettes aux interférences et ont une portée plus grande.

Le récepteur doit être mis dans le boîtier de récepteur, et protégé contre les vibrations par une mousse.

Très important : pour un fonctionnement sans problèmes de la radio et du variateur, il faut utiliser un accu de réception 6V de haute qualité. Nous recommandons les accus réf. 1511903 ou 1511903-1, qui vont bien dans le support d'accu livré avec la voiture.

L'accu doit être connecté avec le récepteur au moyen du câble réf. 1511900. Les câbles de connexion traditionnels, tels qu'ils sont livrés dans les ensembles radio, ne sont pas appropriés.

Attention : Si l'accu de réception n'est pas assez puissant, cela peut entraîner des dysfonctionnements du variateur.



Wild Hunter	# 1571100
	V. 1.0 01.08.2008

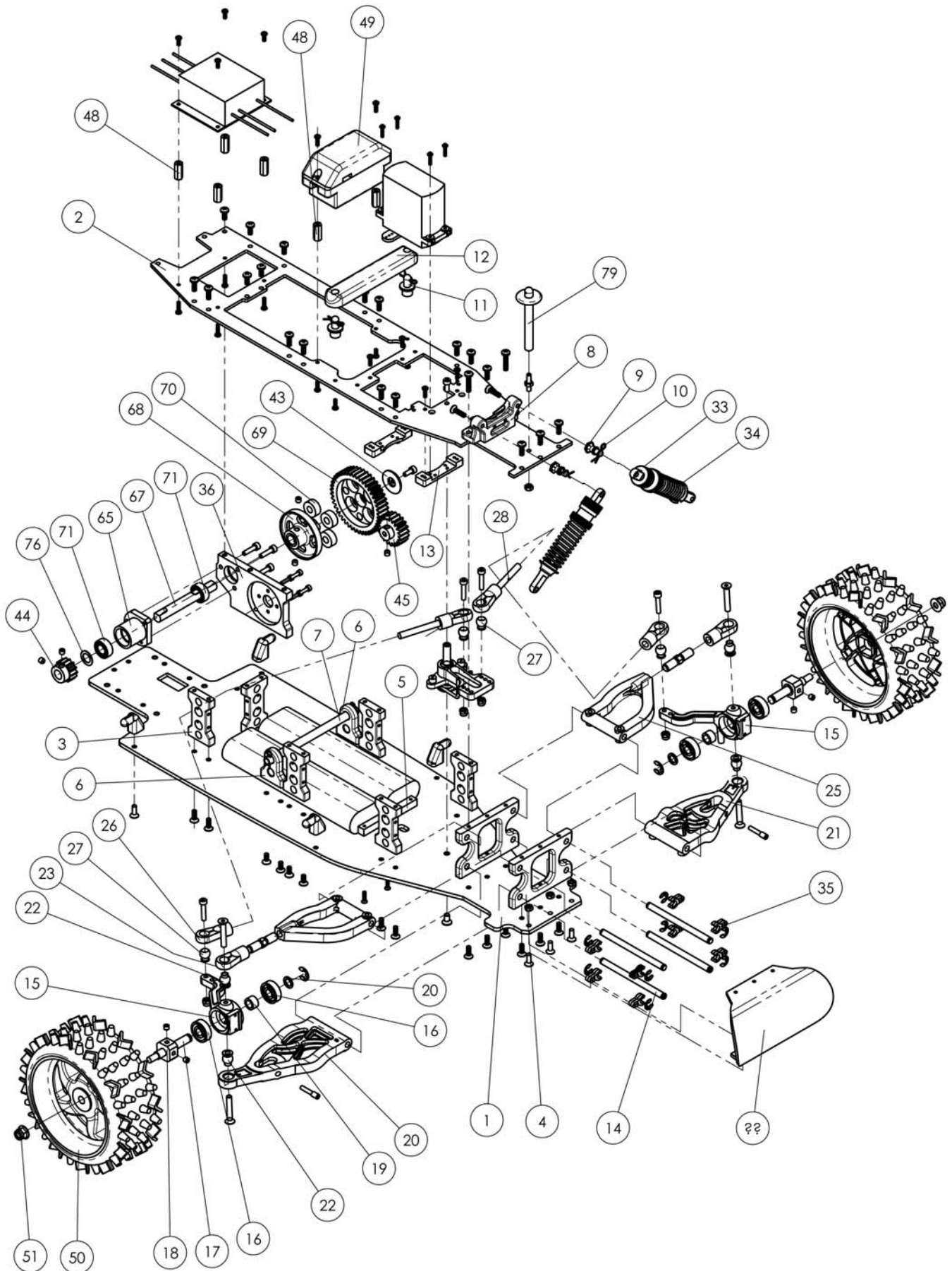



Wild Hunter	# 1571100
	V. 1.0 01.08.2008

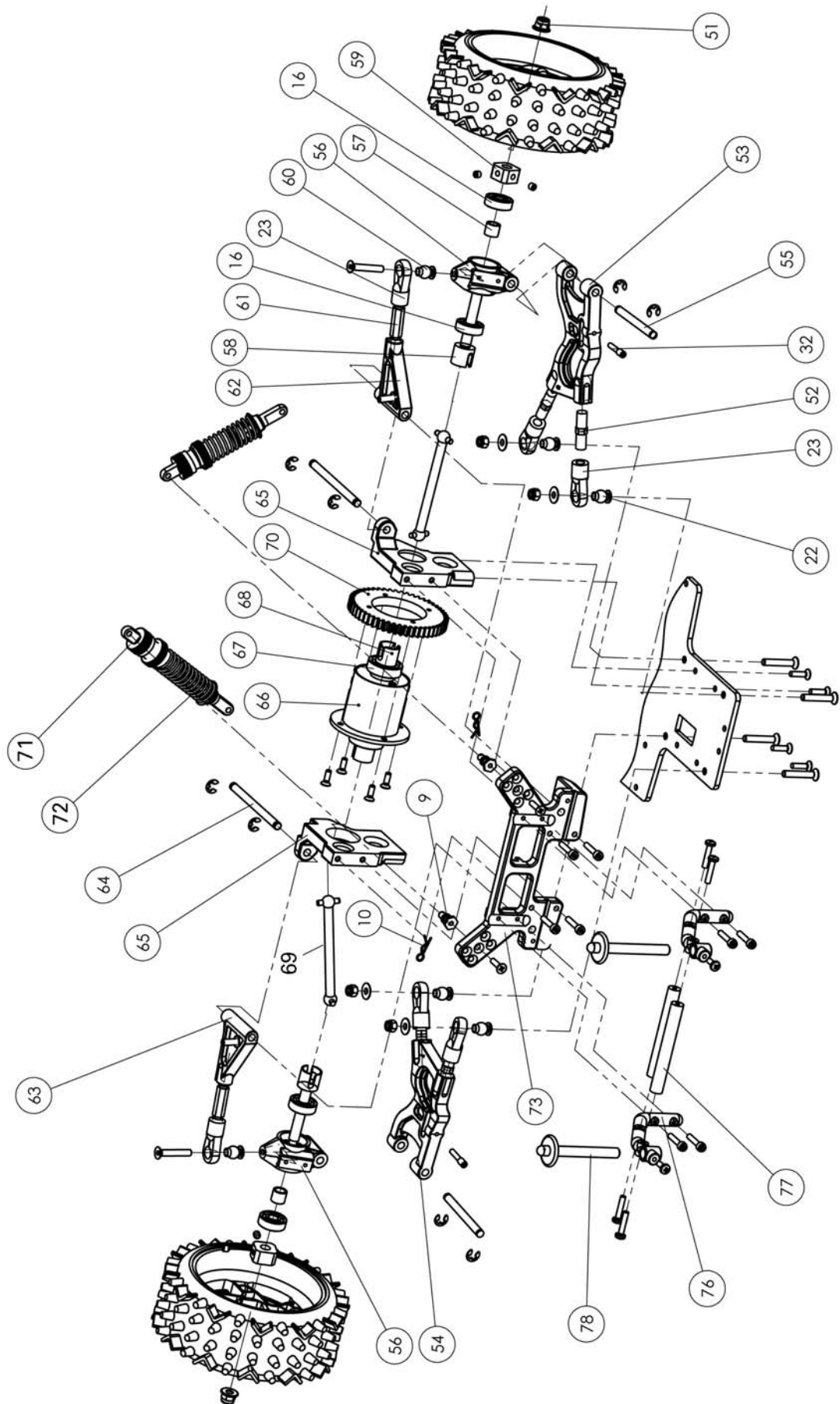



Wild Hunter	# 1571100
	V. 1.0 01.08.2008

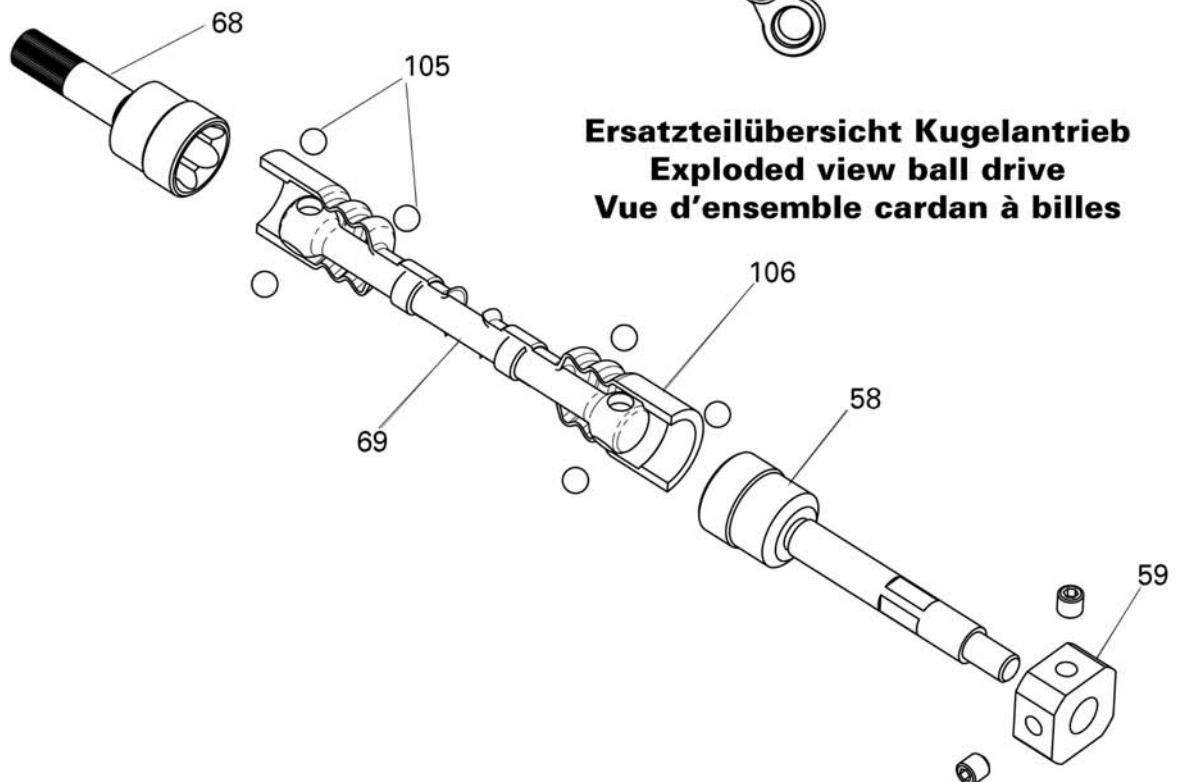
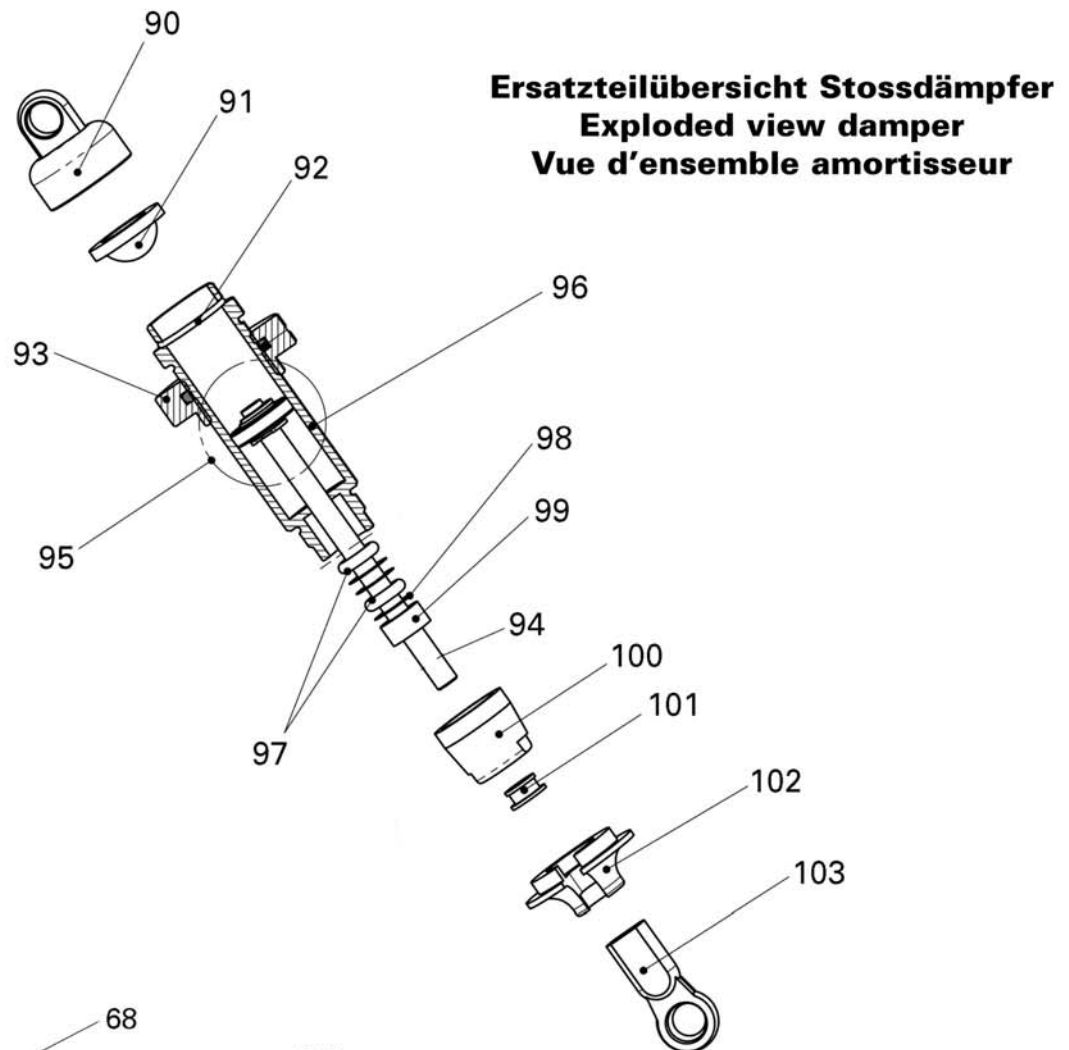



Wild Hunter	# 1571100
	V. 1.0 01.08.2008

Ersatzteile / spare parts / pièces de rechange

			
1) 1572002 Chassisplatte Chassis electro Châssis électrique	(2) 1572012 Chassisoberdeck Upper chassis electro Platine supérieure	(3) 1572020 Chassisabstandshalter Side support Support platine supér.	(4) 1502016 Vorderachsquerplatte Bulkhead Support platine supér. Cellule
			
(5) 1502026 Akku-Anschlagleiste Spacer battery packs Arrêt accu	(6) 1572040 Bock für Akkuhaltestab Support battery tray Fixation support accu	(7) 1572042 Akkuhaltestab Alu Battery support alloy Fixation support accu	(8) 1572030 Dämpferhalteplatte vorne Damper support front Support d'amortisseur
			
(9) 1502836 Dämpferschnellbefest. Damper fixation Support d'amortisseur	(10) 1502835-2 Splinte f. Schnellbefest. Pin damper fixation Goupille d'amortisseur	(11) 1504390 Bolzen f. Akkuhalter Battery tray mount Pivot support accu	(12) 1504397 Akkuhalter Battery tray plastic Support accu plastique
			
(13) 1572020 Servohalter Carson / MPX Servo tray MPX/Carson Support servo MPX/Car.	(13/1) 1572022 Servohalter Hitec Servo tray Hitec 805 Support servo Hitec	(14) 1504145 Querlenkerstift vorne Hinge pin front Axe triangle avant	(15) 1572312 Achsschenkel vorne L+ R Front axle shaft l/r Fusée avant g/d
			
(16) 1503500 Radlager Bearing Roulement	(17) 1504155 Radachse vorne Driving axle front Axe de roue avant	(18) 1504170 Vierkantmitnehmer Hub 17 mm Carré 17 mm	(19) 1511209 Distanzbuchse Spacer front axle shaft Jack fusée avant



Wild Hunter	# 1571100
	V. 1.0 01.08.2008

















Ersatzteile / spare parts / pièces de rechange

			
(20) 1572276 Querlenker vo./u./re. A-arm front lower ri. Triangle av.infér. droit	(21) 1572278 Querlenker vo./u./li. A-arm front lower left Triangle av. inf gauche	(22) 1504130 Stahlkugel M5 Steel ball M5 Rotule acier M5	(23) 1504142 Kugelgelenk schwarz M8 Ball end black M8 Chape noire M8
			
(24) 1572270 Querlenker vo. ob. rechts A-arm front upper ri. Triangle av.supé. droit	(25) 1572272 Querlenker vo. oben links A-arm front upper left Triangle av.sup gauche	(26) 1504204 Kugelgelenk schwarz M6 Ball end black M6 Chape noire M6	(27) 1504120 Stahlkugel 4mm Steel ball 4 mm Rotule acier 4 mm
			
(28) 1504215 Spurst. L+R 75 mm Trackrod l+r 75 mm Pas inversé 75 mm	(29) 1504200 Servosaver-Kunststofftei. parts servo saver Pièces de sauve servo	(30) 1502100 Servosaverwelle Servo saver shaft Axe de sauve servo	(31) 1504195 Servosaverfeder Servo saver spring Ressort de sauve servo
			
(32) 1502901 Befestigungsschraube Damper screw lower Vis d'amortisseur inférieur	(33) 1502821 Stoßdämpfer kurz kompl. Damper short complete Amortisseur complete	(34) 1543655 Dämpferdruckfeder Damper spring 1,9 x 60 Ressort d'amortisseur	(35) 1511255 Abstandsclips sortiert Distance clips sorted Cales réglage chasse
			
(36) 1572050 Getriebepatte Aluminium Transmission bracket alloy Support moteur en alu	(37) 1572055 Getriebewellenhalter Mount transmission shaft Support axe transm.	(38) 1572058 Getriebewelle Transmission shaft Axe de transmission	(39) 1502063 Kugellager Getriebewelle Bearing transmission shaft Roulement axe de transm.

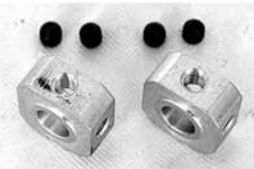

Wild Hunter	# 1571100
	V. 1.0 01.08.2008

Ersatzteile / spare parts / pièces de rechange

			
(40) 1511438 Alu-Zahnradmitnehmer Alloy gear carrier Entraîneur du couronne	(41) 1504265 Dämpfungsgummi Torque ring for pinion Silenbloc entraîneur	(42) 1504270 Kunststoffzahnrad 44 Z Plastic gear 44 teeth Pignon plastique 44 dents	(43) 1502061 Sicherungsscheibe Disk transm. shaft Disque axe de transmission
			
(44) 1532149 Stahlzahnrad 13 Zähne Pinion gear 13 t steel Pignon 13 dents acier	(45) 1572188 Stahlzahnrad 15 Zähne Pinion gear 15 t steel Pignon 15 dents acier	(46) 1573502 Brushless Motor Brushless Motor Moteur brushless	(48) 1572045 Abstandshalter Side support Support
			
(49) 1572390 Empfängerbox Receiverbox Boîte recepteur	(50) 1573530 Drehzahlsteller Controller Variateur	(51) 1511270 Radmuttern spezial Nylock nuts Ecrous spéciaux de roue	(52) 1511315 L.+ R. Gewinde 32 mm Turnbuckle 1/r 32 mm Pas inversé 32 mm
			
(53) 1572280 Querlenker hin. unt. rechts A-Arm rear lower right Triangle arrière infér. droit	(54) 1572278 Querlenker hin. unt. links A-arm rear lower left Triangle arriè. infér.gauche	(55) 1504290 Querlenkerstift hinten Hinge pin rear Axe triangle arrière	(56) 1572310 Achsschenkel hinten Axle shaft rear left + right Fusée arrière gauche/droit
			
(57) 1502510 Distanzbuchse Achssch. Spacer rear axle shaft Jack fusée arrière	(58) 1504310-1 Radachse hinten Driving axle rear Axe de roue arrière	(59) 1504165 Radmitnehmer 14 mm Hub 14 mm Carré 14 mm	(60) 1504137 Stahlkugel hinten oben Steel ball rear upper Rotule acier arr. supérieur



Wild Hunter	# 1571100
	V. 1.0 01.08.2008

Ersatzteile / spare parts / pièces de rechange

			
(61) 1511318 Einstellschraube 49 mm Turnbuckle 49 mm Pas inversé 49 mm	(62) 1572284 Querlenker hin. oben rechts A-Arm rear upper right Triangle arr. supérieur droit	(63) 1572282 Querlenker hin. oben links A-arm rear upper left Triangle a supérieur gauche	(64) 1502550 Querlenkerstift hinten oben Hinge pin rear upper Axe triangle arr. supérieur
			
(65) 1572150 Differentialbock L. + R. Differential mount l/ r Support différentiel g/ d	(66) 1572140 Differential komplett Differential complete Différentiel complète	(67) 1503503 Kugellager Differential Bearing differential Roulement différentiel	(68) 1511461-2 Differentialabtrieb Out drive differential Out drive differential
			
(69) 1504314 Antriebswelle Driving shaft Cardan	(70) 1532196 Stahlzahnrad 52 Zähne Pinion gear 52 t steel Pignon 52 dents acier	(71) 1572822 Stoßdämpfer lang kompl. Damper long complete Amortisseur complet	(72) 1543665 Dämpferdruckfeder 1,8x80 Damper spring 1,8 x 80 Ressort d'amortisseur
			
(73) 1502670 Dämpferplatte hinten Damper support rear Support d'amortisseur	(76) 1504365 Karosseriestütze hinten Body mount rear Support de carrosserie	(77) 1504380 Distanzen Karosseriestütze Spacer for body mount Entretoise support carros.	(78) 1572904 Spoilerhalter hinten wing support support d'aileron
			
(79) 1572015 Karosseriehalter vorne Body mount front, middle Support central carrosserie	(81) 1504250 Karosseriehalter seitlich side supports support lateraux	(84) 1572452 Schraubensatz Wild Hunter Kit screw Wild Hunter Kit visserie Wild Hunter	



Wild Hunter	# 1571100
	V. 1.0 01.08.2008

Ersatzteile / spare parts / pièces de rechange

 <p>(90) 1502821-4 Stoßdämpferkappe kurz Damper cap short Couvercle d'amortisseur</p>	 <p>(91) 1502853 Volumenausgleich Volume compensator d'amortisseur volume</p>	 <p>(92) 1502864 O-Ring Dämpferkappe O-rings for damper cover Joints toriques amortisseur</p>	 <p>(93) 1502849 Verstellung Dämpferfeder Counter ring for shock spring Ecrous molette amortisseur</p>
 <p>(94) 1502855 Kolbenstange kurz vorne Shock shaft ??????? Axe de piston d'amortisseur</p>	 <p>(94) 1502855-1 Kolbenstange lang hinten Shock shaft Axe de piston d'amortisseur</p>	 <p>(95) 1502854 Dämpferkolbenplatte Shock piston Piston d'amortisseur</p>	 <p>(96) 1502821-1 Stoßdämpfergehäuse kurz Shock housing Boîtier amortisseur</p>
 <p>(96) 1502821-2 Stoßdämpfergehäuse lang Shock housing Boîtier amortisseur</p>	 <p>(97) 1502857 O-Ringe Kolbenstange Packing ring for shock Joint spie d'amortisseur</p>	 <p>(98) 1502821-7 Distanzscheiben Spacer for o-ring Rondelle pour bague</p>	 <p>(99) 1502821-6 Führungsbuchse Messing Guide jack Douille de guidage</p>
 <p>(100) 1502821-3 Aufschraubmutter Nut for shock housing Ecrou boîtier amortisseur</p>	 <p>(101) 1502821-8 Führungsbuchse Kunststoff Guide jack plastic Douille de guidage plastique</p>	 <p>(102) 1502856 Federteller Spring collar Bague d'arrêt d'amortisseur</p>	 <p>(103) 1502200 Kugelgelenk 4 mm Ball end 4mm Chapes plastiques 4 mm</p>
 <p>(104) 1502205 Kugeln für 4mm Kugelgelenk Ball for ball end 4 mm Rotules pour chapes</p>			













Wild Hunter	# 1571100
	V. 1.0 01.08.2008

Ersatzteile / spare parts / pièces de rechange

		
<p>(105) 1504308 Kugeln für Kugelantrieb Balls for ball drive set Balls for ball drive set</p>	<p>1504309 Distanzscheiben für Kugelan. Spacer for ball drive Rondelle pour cardan</p>	<p>(106) 1504312 Schutzbalg für Antriebsw. Boots for dog bones Soufflets de cardan</p>

Zubehörteile/accessories/accessoires

			
<p>1511903-1 Empfängerakku 6V / 1600 Receiver battery 6 V/1600 Accu récepteur 6 V/1600</p>	<p>1511903 Empfängerakku 6V / 2500 Receiver battery 6 V / 2500 Accu récepteur 6 V / 2500</p>	<p>1511900 Anschlusskabel f. Empf.-akku Connection f. receiver bat. Cable pour accu récepteur</p>	<p>1511901 Ladekabel für Empf.-akku Loading lead f.receiver bat. Cable de charge p. accu réc.</p>
			
<p>1539460 Reifen soft verкл. Tyre soft glued Pneu soft. collé</p>	<p>1539470 Reifen medium verкл. Tyre med glued Pneu med. collé</p>	<p>1539480 Reifen hart verкл. Tyre hard glued Pneu hard. collé</p>	
			
<p>1573640 GP 3700 6-Zellen 7,2 V Battery pack 3700-6 7,2 V Pneu arrière med. collé</p>	<p>1573641 GP 3700 7-Zellen 8,4 V Battery pack 3700-7 8,4 V Pneu arrière med. collé</p>	<p>1573642 GP 3700 8-Zellen 9,6 V Battery pack 3700-8 9,6 V Pneu arrière med. collé</p>	
			
<p>1573691 Hochstromladekabel High current charging lead Cable de charge accu</p>	<p>1573695 Goldkontakt 5,5 mm Gold plug 5,5 mm Connecteur or 5,5 mm</p>		