

### Vorderachse/front axle

### Achsschenkel vorne/front axle hubs

- |                                                               |                                                               |
|---------------------------------------------------------------|---------------------------------------------------------------|
| <input type="checkbox"/> Standard                             | <input type="checkbox"/> Standard                             |
| <input type="checkbox"/> deachsiert/off-set 1,5 mm            | <input type="checkbox"/> deachsiert/off-set 1,5 mm            |
| <input checked="" type="checkbox"/> deachsiert/off-set 3,0 mm | <input checked="" type="checkbox"/> deachsiert/off-set 3,0 mm |

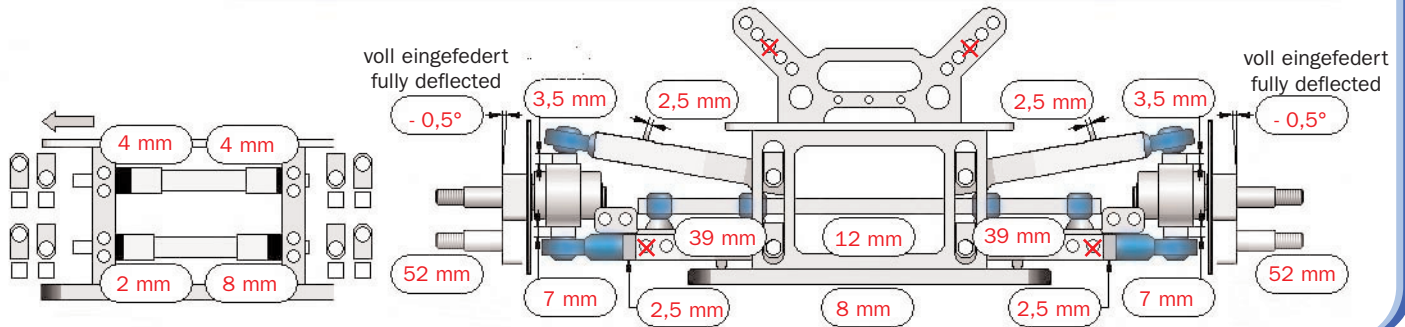

### Hinterachse/rear axle

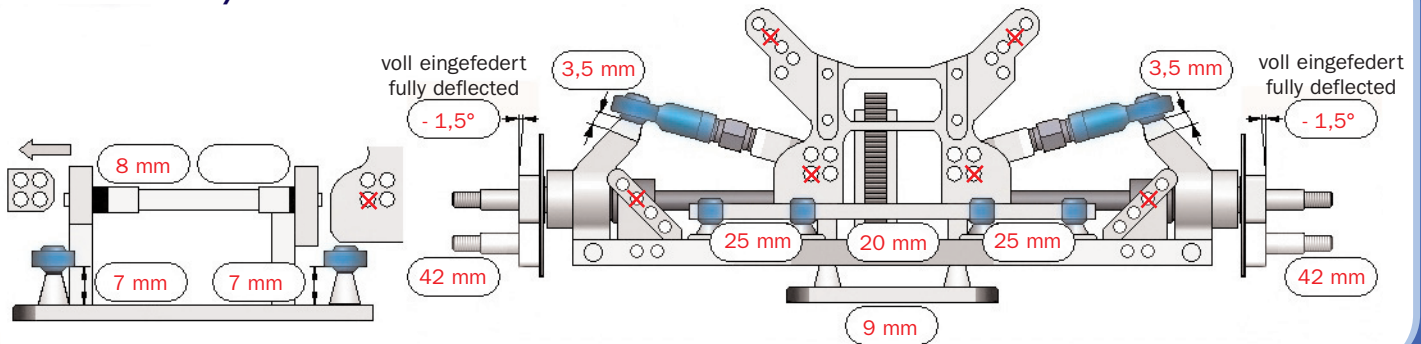

### Vorderachse front axle

### Hinterachse rear axle

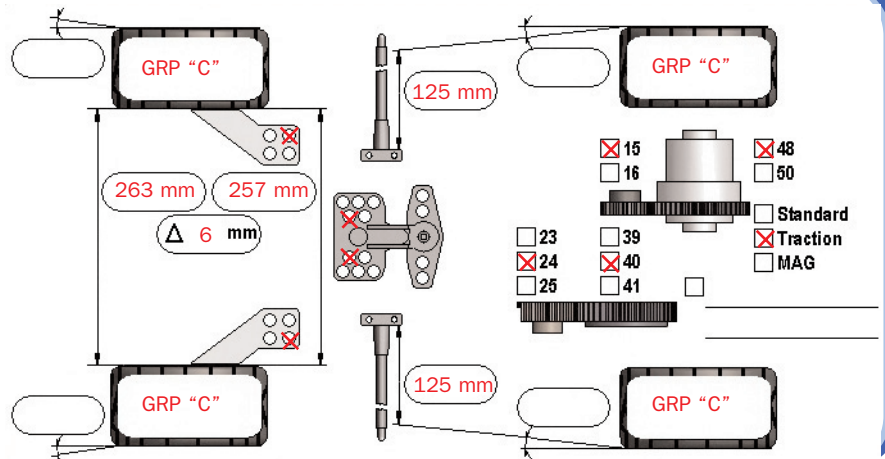
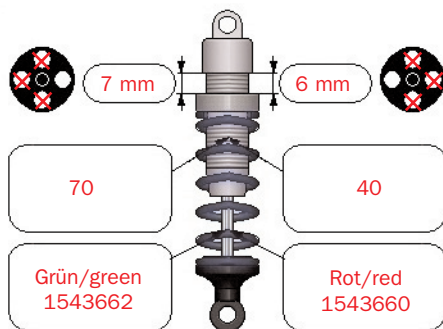

Karosserie/body: \_\_\_\_\_

Gewicht/weight: \_\_\_\_\_

Motor: \_\_\_\_\_

Wetter/weather: \_\_\_\_\_

Reso/pipe: \_\_\_\_\_

Temperatur/temperature: \_\_\_\_\_

Airbox: \_\_\_\_\_

Temperatur Rennstrecke/temperature race track: \_\_\_\_\_

Kupplung/clutch: \_\_\_\_\_

Notizen/notice: \_\_\_\_\_