

Vorderachse/front axle

Achsschenkel vorne/front axle hubs

- | | | |
|---|---------------------------|-------------------------------------|
| <input type="checkbox"/> Standard | Standard | <input type="checkbox"/> |
| <input checked="" type="checkbox"/> deachsiert/off-set 1,5 mm | deachsiert/off-set 1,5 mm | <input checked="" type="checkbox"/> |
| <input type="checkbox"/> deachsiert/off-set 3,0 mm | deachsiert/off-set 3,0 mm | <input type="checkbox"/> |

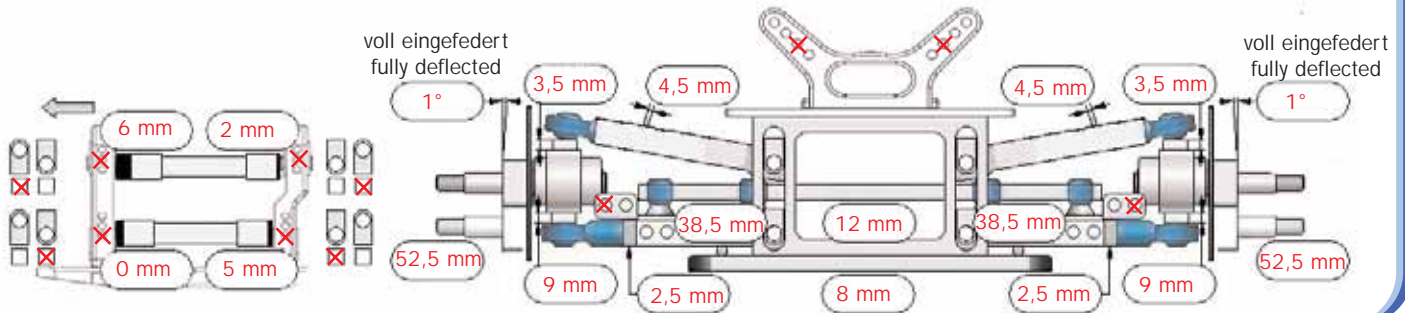

Hinterachse/rear axle

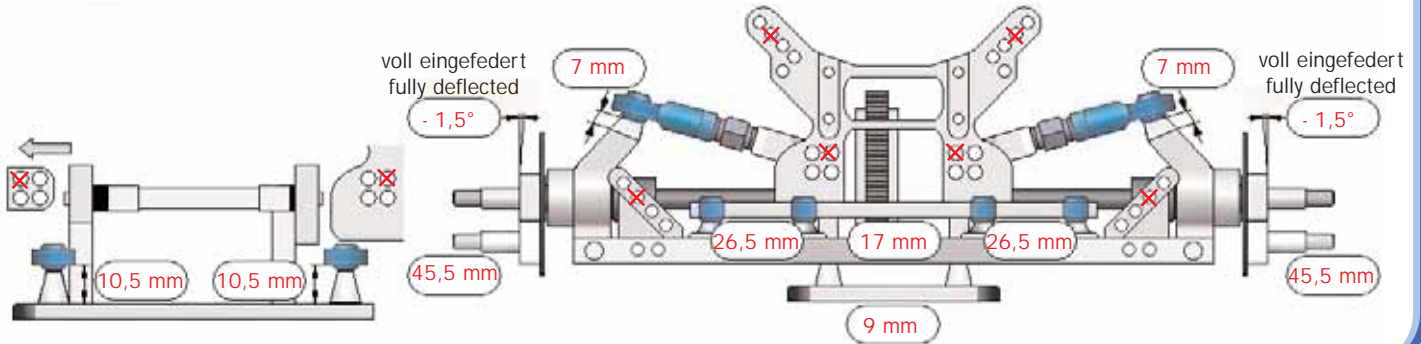

Vorderachse front axle

Hinterachse rear axle

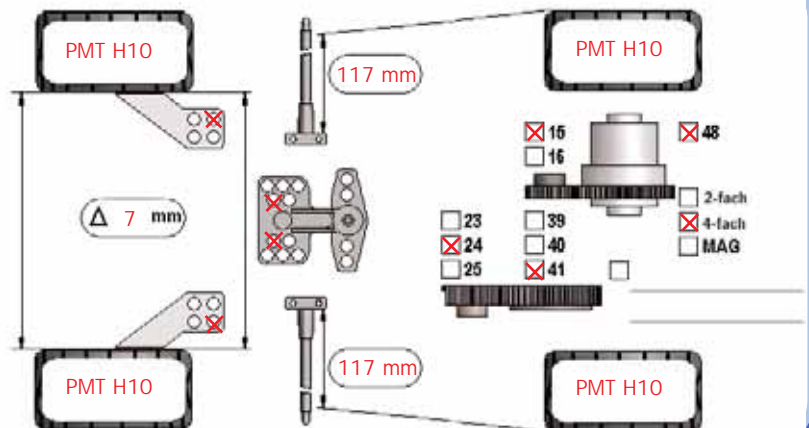
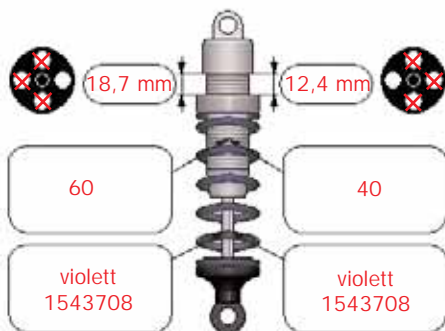

Karosserie/body: BMW 320si

Gewicht/weight: 10,1 Kg

Motor: HRP03 240

Notizen/notice: Tuning-Direktstabi vorne / tuning direct stabilizer front

Reso/pipe: Mielke Hurrican

Tuning-Stabhalter vorne und hinten / tuning stabilizer support front and rear

Airbox: Mielke Open Up

Tuning-Stoßdämpferhalter vorne unten / tuning damper support front lower

Kupplung/clutch: 3-Backen / 3-shoe clutch