

Vorderachse/front axle

Achsschenkel vorne/front axle hubs

- | | |
|---|---|
| <input type="checkbox"/> Standard | <input type="checkbox"/> Standard |
| <input checked="" type="checkbox"/> deachsiert/off-set 1,5 mm | <input checked="" type="checkbox"/> deachsiert/off-set 1,5 mm |
| <input type="checkbox"/> deachsiert/off-set 3,0 mm | <input type="checkbox"/> deachsiert/off-set 3,0 mm |

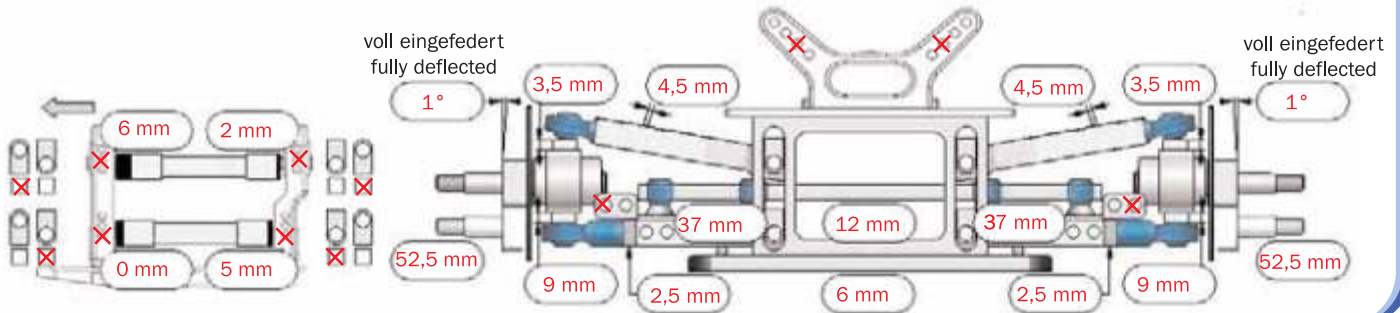

Hinterachse/rear axle

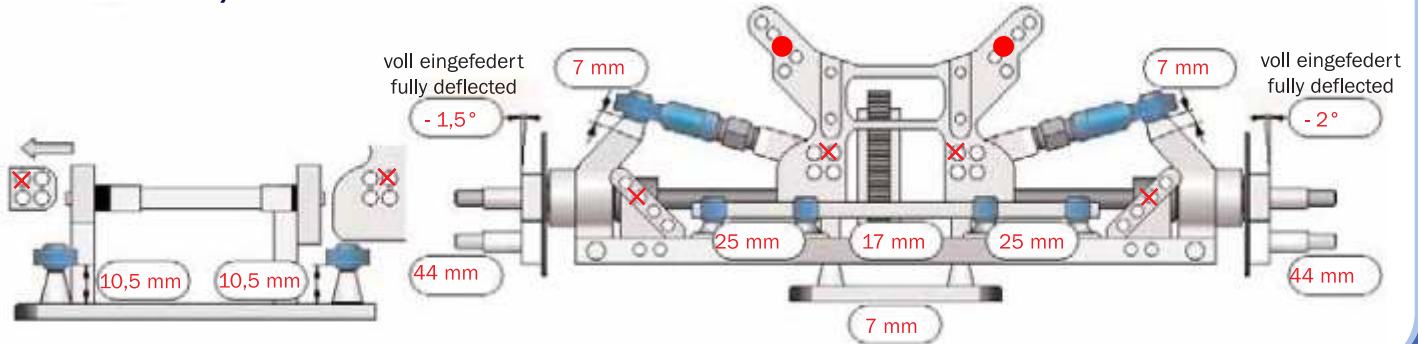

Vorderachse front axle

Hinterachse rear axle

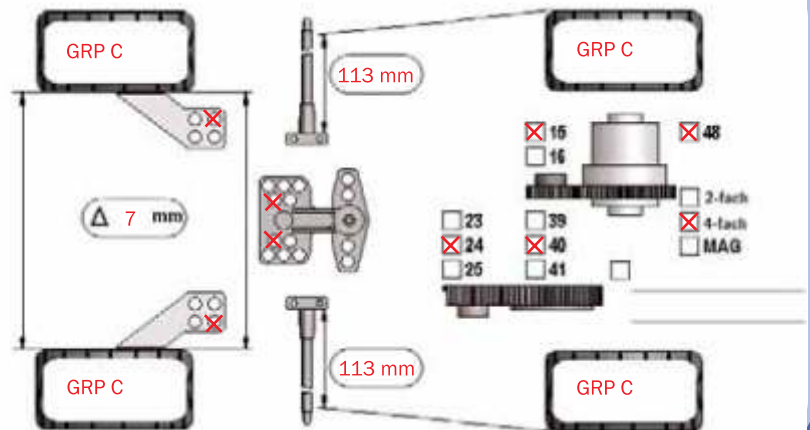
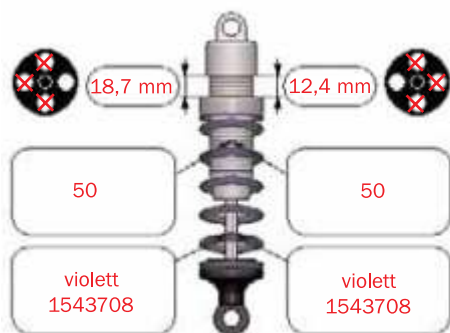

Karosserie/body: Alfa Dito Dito

Gewicht/weight: 10,25 Kg

Motor: Rc240

Notizen/notice: Tuning-Direktstabi vorne / tuning direct stabilizer front

Reso/pipe: Mielke Hurrican

Tuning-Stabilhalter vorne und hinten / tuning stabilizer support front and rear

Airbox: Bergonzoni

Tuning-Stoßdämpferhalter vorne unten / tuning damper support front lower

Kupplung/clutch: HARM BDC-3