



BX-3

2 WD Offroad

Name/name: _____

Datum/date: _____

Rennstrecke/race track: _____

Vorderachse/front axle

Nachlauf/caster front axle



Abstandsclips/Distance clips
vorne/front hinten/rear

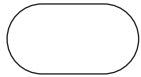

Bodenfreiheit und Achsschenkel vorne
ride height and axle hub front

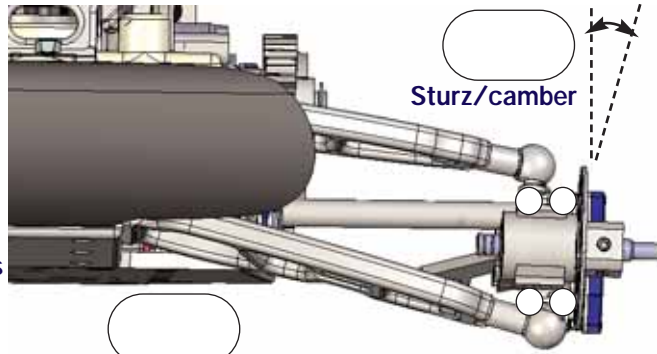

Sturz/camber



Dämpferposition vorne
damper position front

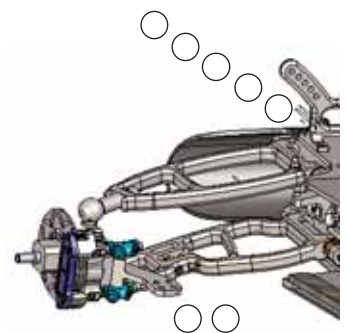

Ackermann/Reifen/Untersetzung/Ackermann/tyres/reduction

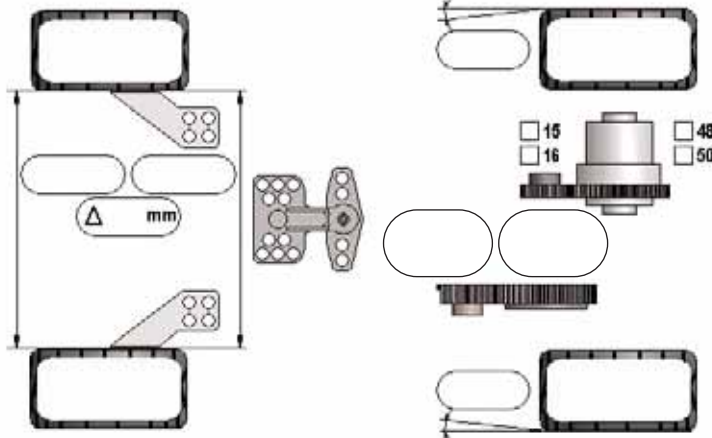

Querlenkeraufnahme hinten unten/
Bulkhead rear lower

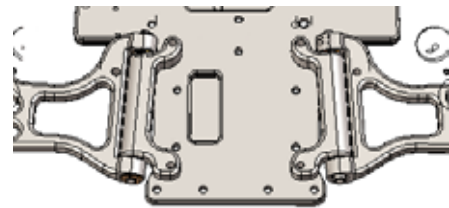

- 2° Vorspur/2° toe-in
- 4° Vorspur/4° toe-in
- 4° Vorspur - 5° Nachlauf/4° toe-in - 5° caster

Stoßdämpfer/shocks

Vorne/front

Dämpferkolben vorne/
shock piston front

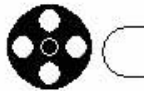

Öl/oil

Feder/spring

Hinten/rear

Dämpferkolben hinten/
shock piston rear



Öl/oil

Feder/spring



Position Motor und Servoplatte/ position motor and servo plate

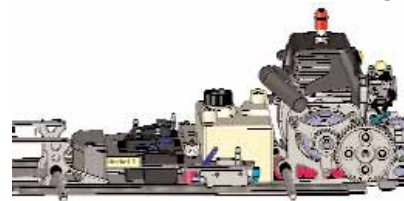

- Motor stehend, Servoplatte hinten/
Motor vertical, servo plate in rear position
- Motor stehend, Servoplatte vorne
Motor horizontal, servo plate in front position



- Motor liegend, Servoplatte vorne/
Motor horizontal, servo plate in front position



BX-3

2 WD Offroad

Name/name: _____

Datum/date: _____

Rennstrecke/race track: _____

Dämpferposition hinten
damper position rear

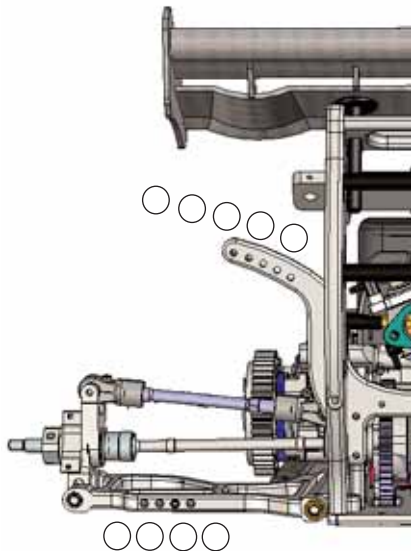

Hinterachse/rear axle

Querlenkerpositionen hinten
a-arm positions rear

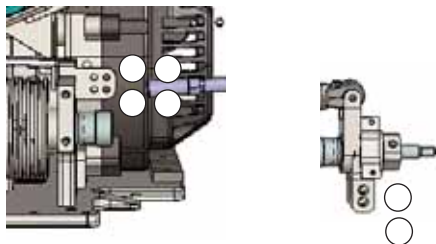

Spoilerposition
position of the wing



Motor: _____

Reso/pipe: _____

Kupplung/clutch: _____

Einkuppeldrehzahl/engaging engine speed: _____

Gewicht/weight: _____

Bodenfreiheit und Sturz hinten
ride height and camber rear

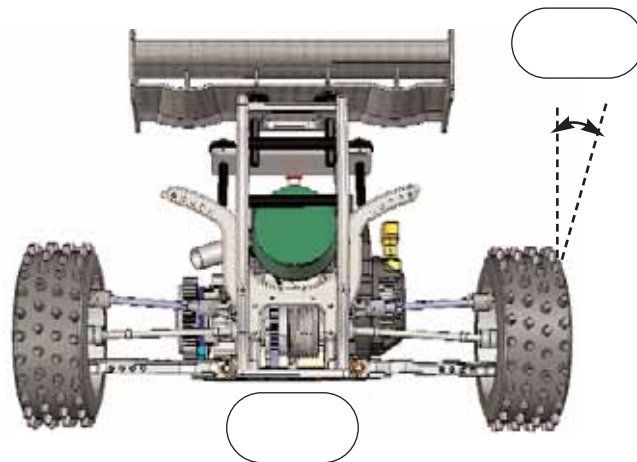

Beschreibung der Rennstrecke, Bodenbeschaffenheit/
description of the track, nature of the ground

Notizen/notice:

